

AAP126

NGV Filter Housing

Materials	Aluminium 6082
Pressure	250 Bar
Ports	1/4" NPT or SAE-6
Element	12.57.CP□

AAP126 series high pressure NGV filter housings have an anodised head and bowl machined from solid aluminium 6082 bar stock. These coalescing filter housings are suitable for use with compressed natural gas in alternative fuel systems for on-vehicle applications.

Designed for use with the 12.57.CP□ coalescing filter cartridge the housings are supplied with 1/4" NPT or SAE-6 ports and a plugged drain port for easy drainage of any coalesced liquids.

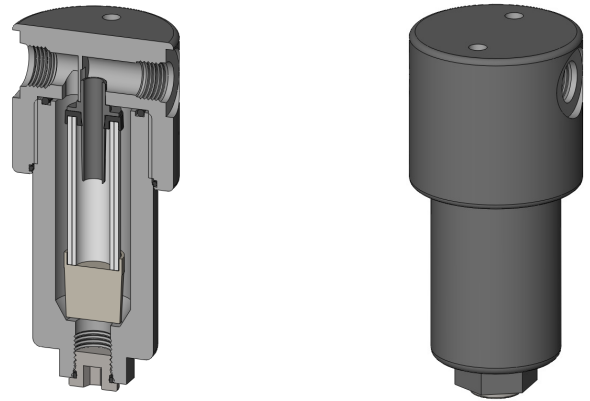

AAP126 NGV Filter Housing

Technical Specifications

Housing Model	AAP126.251	AAP126.554
Port Size	1/4" NPT	SAE-6 (9/16"-18)
Drain	SAE-6 Drain Plug	SAE-6 Drain Plug
Maximum Pressure, Bar	248	248
Minimum Burst Pressure, Bar	1000	1000
Temperature Range, °C	-40°C to +125°C	-40°C to +125°C
Materials of Construction		
Head & Bowl	Aluminium 6082	Aluminium 6082
Head Insert	Polyamide	Polyamide
Seals	Fluoroelastomer (FKM)	Fluoroelastomer (FKM)
Filter Cartridge Code (1)	12.57.CP□	12.57.CP□
Principal Dimensions in mm		
Diameter	60	60
Height	132	132
Volume of Sump, cc	15	15
Weight, kg	0.42	0.42
Accessories		
Mounting Bracket	MBAAC11	MBAAC11

Notes

(1) Replace the □ with the grade required, e.g. 12.57.CP7CS



Contact Us

Classic Filters Ltd.
Sextant Park
Neptune Close
Rochester
Kent
England
ME2 4LU

T +44 (0)1634 724224
F +44 (0)1634 724234
E info@classicfilters.com
W www.classicfilters.com

Follow Us



<http://www.linkedin.com/company/classic-filters-ltd.>



<http://www.twitter.com/classicfilters>